

Pecora 985

Structural Silicone Sealant

Specification Data Sheet



1. BASIC USES

Pecora 985 is a fast curing two-part, high-modulus, neutral-cure silicone sealant specially formulated and compounded for use in shop-fabrication of structurally glazed curtainwall systems.

2. MANUFACTURER

Pecora Corporation
165 Wambold Road
Harleysville, PA 19438
Phone: 215-723-6051
800-523-6688
Fax: 215-721-0286
Website: www.pecora.com

3. PRODUCT DESCRIPTION

The sealant is virtually unaffected by ultra violet rays, ozone, temperature extremes or atmospheric contamination and is compatible with a variety of plain and coated metals, high-performance glass, decorative paints, gaskets, setting blocks and spacers. (see note on page 2)

Features of Pecora 985:

- high tensile strength.
- excellent working properties.
- adjustable cure rate of 20 to 60 minutes allowing for fast fabrication and early movement of completed units.
- no lot matching of base and activator required.
- unprimed adhesion to glass, reflective-glass coatings, anodized aluminum and other metals and most fluorocarbon paints. (see priming)
- negligible sag or slump.
- no corrosive by-products or objectionable odor.

Limitations: Conditions under which Pecora 985 should not be used:

- in conjunction with acid-curing silicone sealants as this could result in loss of adhesion of the 985.
- where contact will be made with materials that bleed oils, plasticizers or solvents, i.e. impregnated wood, oil-based caulks, green or partially vulcanized rubber gaskets or tapes.
- in below-grade or submerged installations.

- in designs that require painting of the sealant.

4. TECHNICAL DATA

PACKAGING

- 55-gallon kits (208 L)
- 50-gallons (189 L) Part A Base and
- 5-gallons (18.9 L) Part B Curing Agent

COLOR

- Dark Gray

Applicable Standards: Pecora 985 meets or exceeds the following: TT-S-00230C, Class A, Type II; ASTM C-920, Class 25, Type M, Grade NS, Use G,A,O; ASTM C-1184-05: AAMA 802.3-08, Type I; Missile Impact Miami-Dade PA 201 and SSID 12-99.

Design: The design professional is responsible for the determination of the structural sealant joint dimension based on design windloads, glass sizes and anticipated thermal movement. Pecora must verify and approve joint dimensions on an individual project basis.

Basic Design Parameters Include:

- Structural sealant thickness must not be less than 1/4" (6 mm).

- Structural bite must not be less than structural sealant thickness.
- Structural bite must be determined using the following formula:

$$\frac{W.L. \times (1/2) S}{12 \times 20} = C.W.$$

S = Short span of glass, feet

W.L. = Windload, PSF

Constant = 12

Design Stress, psi Max. = 20

C.W. = Contact width

- The structural sealant joint must be able

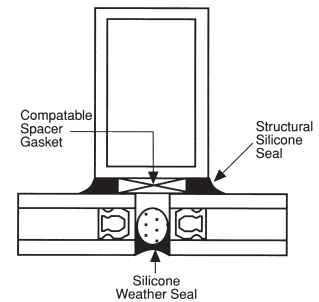

to be filled using standard caulking practices.

- The structural joint must not move during cure.

TYPICAL PHYSICAL PROPERTIES

Test Property	Value	Test Procedure
As Supplied - Base		
Color	White	
Specific Gravity	1.20	ASTM D2320
Storage Life (months)	12	Pecora Corporation
As Supplied - Curing Agent		
Color	Black	
Specific Gravity	1.03	ASTM D2320
Flammability	Non-Flammable	ASTM D1310
Storage Life (months)	12	Pecora Corporation
After Mixing*		
Color	Dark Gray	
Specific Gravity	1.18	ASTM D2320
Working Time (minutes)	15	Pecora Corporation
Corrosiveness	Non-corrosive	ASTM D3310
Consistency	Non-slumping	ASTM D2202
VOC (g/L)	60	ASTM D3960
As Cured - 7 Days at Room Temperature		
Shore A	35	ASTM D2240
Elongation (%)	275	ASTM D412
Tensile Strength (psi)	206	ASTM D412
Movement Capability (%)	+25	ASTM C719
Cold Flow, Creep	Negligible	ASTM D2294
Heat Resistance (°F (°C))	300 (148)	Pecora Corporation
Stress @ 100% Extension (psi)	88	ASTM C1135

*Mixed by weight 12:1 or by volume at 10:1 base-to-curing-agent ratio.

These are preliminary guidelines only, consistent with common industry practice. PECORA CORPORATION GIVES NO BLANKET APPROVAL FOR STRUCTURAL GLAZING APPLICATIONS. TECHNICAL BULLETIN #56 OFFERS A STRUCTURAL GLAZING APPRAISAL PROGRAM DESIGNED TO REDUCE THE RISK FOR ALL PROJECT PARTICIPANTS. STRUCTURAL PROJECT DETAILS MUST BE REVIEWED BY PECORA AND ALL SYSTEM COMPONENTS PRETESTED FOR ADHESION AND COMPATIBILITY BEFORE APPROVAL IS GIVEN.

5. INSTALLATION

Surface Preparation: No sealant will maintain long-term adhesion if the substrate is not properly cleaned before the sealant is applied. Thoroughly clean joint and glazing areas with solvent to remove all foreign material and contaminants such as oil, dust, grease, frost, water, old sealants or glazing compounds and any protective coatings. (see *caution)

Cleaning of surfaces should be done just prior to the sealant's application. Soap or detergent and water solutions should not be used to clean lest they leave a form release film on the surface.

Structural glazing requires even greater attention to surface cleaning. Bulletin #56 addresses the proper procedures in greater detail.

Priming: Pecora 985 does not require priming in most cases. However, unusual materials, special coatings and surface treatments may impair adhesion. Because of the unpredictability of such surfaces, a lab test is recommended to check adhesion with and without primer. If primer is necessary, P-120 should be used on metal. Should a porous surface be involved, P-64 is to be used. Primer is never required on uncoated glass.

Note: Pecora welcomes the opportunity to conduct adhesion and compatibility tests in its laboratory on substrates to be sealed on the project. Actual samples from the job are preferred although representative samples are acceptable, keeping in mind that representative samples often differ from material actually supplied on the job.

Masking: Areas adjacent to joints should be masked to assure neat sealant line. Do not allow tape to touch clean surfaces to which sealant is to adhere.

Application: Install backup fillers, setting blocks, spacer shims and tapes as specified. Apply 985 silicone in one continuous operation. Tool sealant at once after application. Tool concave with a firm continuous stroke to assure complete sealant contact with the substrate and present a neat appearance. Remove masking tape. In glazing applications be sure that the sealant is tooled at the sills so that precipitation and cleaning solutions will not pool. Pecora 985 silicone can be applied at temperatures as low as -15° F provided all surfaces are dry and frost free.

Application (Pot) Life: Depends on rate of cure and relative humidity conditions. Variable cure rate ("snap time") of 10 to 25 minutes may be obtained by adjusting the Base/Activator ratio as shown in the following graph. 985 curing agent should be stirred before use because settling can occur during shipment.

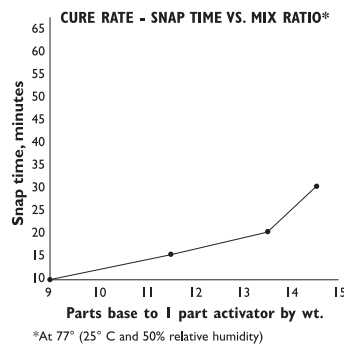

Cleaning: Excess sealant should be removed from all surfaces while still uncured using solvents such as Toluene, Xylene or Methyl Ethyl Keytone (MEK).* Cured sealant is very difficult or impossible to remove completely without altering or damaging the surfaces to which the sealant has been misapplied.

***CAUTION:** Solvents used in cleaning may be toxic and/or flammable. Refer to solvent manufacturer's instructions and Material Safety Data Sheet.

Precautions: Use with adequate ventilation or wear an appropriate NIOSH-approved respirator. Contact with uncured sealant or with vapors generated during curing may cause respiratory tract irritation. Contact with skin or eyes may cause irritation or allergic reaction. Avoid contact and wash thoroughly after handling. May be harmful if swallowed. Refer to Material Safety Data Sheet (MSDS) for more information.

**FOR PROFESSIONAL USE ONLY.
KEEP OUT OF THE REACH
OF CHILDREN.**

6. AVAILABILITY AND COST

Pecora products are available from stocking distributors nationwide. For the name and telephone number of your nearest representative, call the number below or visit our website at www.pecora.com.

7. WARRANTY

Pecora Corporation warrants its products to be free of defects. Under this warranty, we will provide, at no charge, replacement materials for, or refund the purchase price of, any product proven to be defective when used in strict accordance with our published recommendations and in applications considered by us as suitable for this product. The determination of eligibility for this warranty, or the choice of remedy available under this warranty, shall be made in our sole discretion and any decisions made by Pecora Corporation shall be final. This warranty is in lieu of any and all other warranties, expressed or implied, including but not limited to a warranty of merchantability or fitness for a particular purpose and in no case will Pecora be liable for damages other than those expressly stated in this warranty, including but not limited to incidental or consequential damages.

8. MAINTENANCE

If the sealant is damaged and the bond is intact, cut out the damaged area and recaulk. No primer is necessary. If the bond has been affected, remove the sealant, clean and prepare the joint in accordance with the instructions under "INSTALLATION".

9. TECHNICAL SERVICES

Pecora representatives are available to assist you in selecting an appropriate product and to provide on-site application instructions or to conduct jobsite inspections. For further assistance call our Technical Service Department at 800-523-6688.

10. FILING SYSTEMS

- Sweet's Catalog File: www.sweets.com
- General Building
 - 07100 Waterproofing
 - 07920 Sealants
- Civil Engineering
 - 07100 Waterproofing



PEOPLE • PRODUCTS • PERFORMANCE

www.pecora.com